

GIANTMIX FR LIGHT

FR 40-220
FR 40-305
FR 75-380
FR 75-460

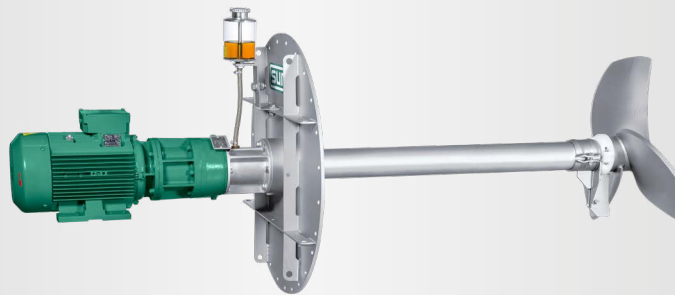

Application

Rod agitator for small steel- or concrete tanks
 Dry matter content up to 12 %
 Substrate temperature up to 160 F
 pH-values 6.5 - 8.2

Bearing

2 tapered roller bearings to absorb the axial forces
 Mechanical seal SiC/SiC independent of rotation direction
 Interim bearings in drive shaft

Technical Data

Tube length 3.3 / 5.0 ft
 Sealing plate DN700 (Ø 34 in), other dimensions on request
 Sealing plate with other angle of inclination on request
 Sound pressure 75 dB(A)
 Oil equalizing container for monitoring the tightness
 POM protection to minimize abrasion

Propeller

3-bladed, dynamically balanced propeller

FR 40-220	5.4 hp	220 rpm	propeller HD+ 640
FR 40-305	5.4 hp	305 rpm	propeller HD+ 540
FR 75-330	10.0 hp	330 rpm	propeller HD+ 620
FR 75-460	10.0 hp	460 rpm	propeller HD+ 480

ss304, optional galvanized or hardened steel

Motor

5.4 hp (6-poles) / 10.0 hp (), 60 Hz
 PTC thermistors as overheat protection
 Ex-Motor II 3G Ex nA IIC T3 Gc (Ex-Zone 2)

Ex-Zone

Ex-zone 2 (outside the tank)
 and zone 1 (inside the tank)
 Classification mechanical components
 II 2G h IIA T3 Gb

Gear

Planetary gear
 Reduction ratio $i = 3.83$ or 5.25
 Separate oil chamber, gear oil Blasias SX 320
 10,000 operation hours between oil changes

Controls (optional)

Star-delta switch, soft start or frequency converter
 Delivery without connecting cable

Tube

Tube 4 x 0.2 in ss304 or ss316 on request
 Plug shaft Ø 1.97 in with intermediate bearings and both sided-plug-connections



GIANTMIX FR LIGHT

FR 40-220

FR 40-305

FR 75-330

FR 75-460

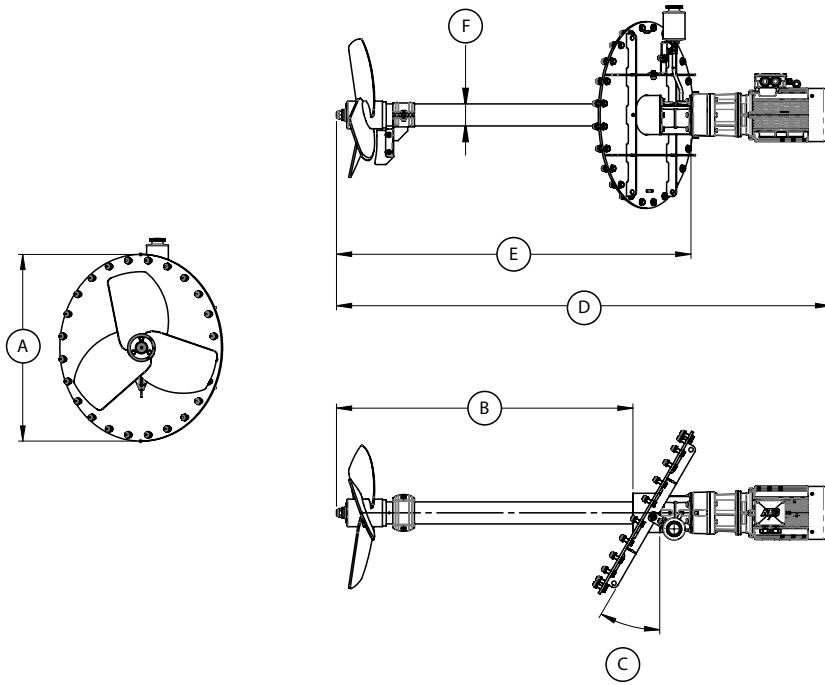

Dimensions

Type	A [in]	B [in]	C	D [in]	E [in]	F Ø [in]
FR 40-220 FR 40-305 FR 75-330 FR 75-460	33.9	34.4 / 54.1	0° / 10° / 20° / 30°	70.1 / 89.8	44.7 / 64.4	4.0

Technical data

Type	Rated power [hp]	Frequency [Hz]	Gear reduction ratio	Propeller speed [rpm]	Propeller diameter [in]	Axial force [lbf]	Flow velocity [ft/s]	Pumping rate Water [gal/min]*	Weight approximate [lbs]			
FR 40-220	5.5	60	5.25	220	25.2	224	7.5	11,360	507			
FR 40-305	5.5	60	3.83	305	21.3	224	7.9	8,190	507			
FR 75-330	10.0	60	5.25	330	24.4	404	10.2	14,265	507			
FR 75-460	10.0	60	3.83	460	18.9	382	9.8	7,925	507			

Subject to change without notice

* measured in water at 3.94 ft distance

As per: 2023-08

© SUMA America Inc. | 2700 Patriot Blvd Suite 400 | Glenview, IL 60026

Phone: 312.912.1961 | Email: sales@gosuma.com | www.gosuma.com