

## GIANTMIX FR STATIONARY

**FR3 110-480**

**FR4 150-480**

**FR5 185-480**



### Application

Long-axis agitator for stationary installation  
 Dry matter content up to 14 %  
 Substrate temperature up to 70°C  
 pH-value 6.5 - 8.2

### Bearing

2 tapered roller bearings to absorb the axial forces  
 Mechanical seals in SiC/SiC, independent of rotation direction  
 Interim bearings for the drive shaft, slide bearing

### Technical Data

Tube length 8.2 / 9.8 ft  
 Tube Ø 4 x 0.16 or 0.22 in in ss304  
 Sound pressure level 75 dB(A)  
 Installation up to 19.7 ft below substrate level possible,  
 deeper immersion depths on request  
 Oil inspection glas for monitoring the tightness  
 Option: Rubber compression seal Ø 7.9 in, galvanized  
 Optional PTO with protection unit for an alternative tractor  
 operation (max. HD+ 700)  
 Agitator completely in modular design  
Accessory: POM protection to minimize abrasion

### Propeller

3-blade high efficiency propeller,  
 dynamically balanced

FR3:	15.0 hp	480 rpm	propeller HD+ 500
FR4:	20.0 hp	480 rpm	propeller HD+ 540
FR5:	25.0 hp	480 rpm	propeller HD+ 580

Standard in ss304  
 optional ss316 or hardened steel

### Ex-Zone

Ex-Zone 2 (outside the tank) and Zone 1 (inside the tank)  
 Special version FR4 with 18.0 hp for Zone 1  
 (outside tank)  
 Classification mechanical components:  
 CE Ex II 2G ck IIA T3

### Control box (optional)

Star-delta-switch, soft starter, frequency converter  
 Delivery without connecting cable

### Motor

15.0 / 20.0 / 25.0 hp : 4 poles  
 PTC thermistors PTC 160°C as overheat protection  
 Ex-Motor (Series) Ex II 3G Ex nA II T3 Gc  
 Special version with 18.0 hp Ex II 2G Ex e IIA T3 Gb  
 Optional: rain protection hood (ss304)

### Gear

Spur gear drive, helical teeth, low noise level  
 Reduction ratio  $i = 3.69$   
 Oil chamber, gear oil SAE85W-140 / API GL-5  
 Oil change interval after 2,000 operating hours

### Control box (optional)

Star-delta switch, soft start or frequency converter  
 Delivery without connecting cable



## GIANTMIX FR STATIONARY

**FR3 110-480**

**FR4 150-480**

**FR5 185-480**

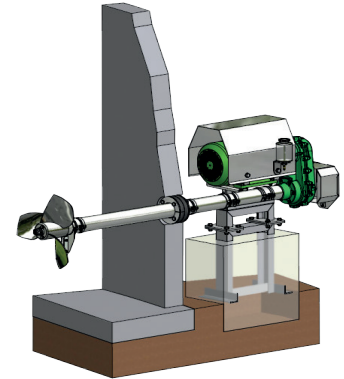
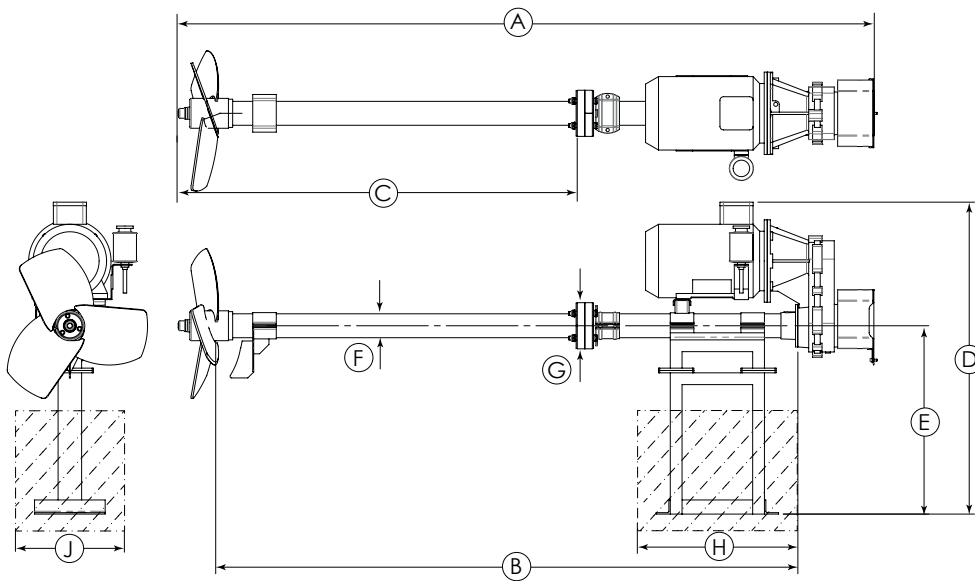

### Dimensions

Type	A [ft]	B [ft]	C [ft]	D [in]	E [in]	F [in]	G [in]	H [in]	J [in]		
FR 3-5	9.8 / 11.5	8 / 9.8	5 / 6.9	52.2	31.5	4	7.9	31.5	19.7		

### Technical data

Type	Rated Power [hp]	Propeller speed [rpm]	Frequency [Hz]	Gear reduction ratio	Propeller diameter [in]	Axial force [lbf]	Flow velocity [ft/s] *	Pumping rate Water [gal/min]	Weight approximate [lbs]		
FR3	15.0	480	60	3.69	19.7	494	11.8	10,566	661		
FR4	20.0	480	60	3.69	21.3	607	13.8	14,529	661		
FR5	25.0	480	60	3.69	22.9	719	13.5	16,378	661		

Subject to technical changes

\* measured in water and 3.94 ft distance

As per: 2018-07

© SUMA America Inc. | 2700 Patriot Blvd Suite 250 | Glenview, IL 60026

Tel: (312) 945 9049 | E-mail: sales@gosuma.com | www.gosuma.com