

GIANTMIX BG2

BG2 40-220

BG2 40-305

BG2 75-330

BG2 75-460

BG2 100-330

BG2 100-460



Application

Long axis agitator for lagoons
 Dry matter content up to 12 %
 Substrate temperature up to 160 F
 pH-values 6.5 - 8.2

Tube

Tube 4.0 x 0.2 in, ss304 - ss316 on request
 Stub shaft Ø 2.0 in with multiple idler bearings and both sided plug-connection

Technical data

Tube length 13 / 16.5 ft
 Foil clamp unit, Ø 29.5 in, stainless 304 for BG2 75-460
 Sound pressure level 75 dB(A)
 Oil inspection glass for monitoring the tightness

Motor

Power: 5.5 / 10 / 13.5 hp
 PTC thermistors as overheat protection
 Ex-Motor  II 3G Ex nA IIA T3 Gc (Ex-zone 2)

Gear

Planetary gear, helical cut, low noise
 Reduction $i = 3.83$ or 5.25
 Own oil chamber, gear oil Blasias SX 320
 10,000 operating hours between oil changes

Propeller

3-bladed, dynamically balanced propeller

BG2 40-220	5.5 hp	propeller HD+640	220 rpm
BG2 40-305	5.5 hp	propeller HD+ 540	305 rpm
BG2 75-330	10. hp	propeller HD+ 620	330 rpm
BG2 75-460	10. hp	propeller HD+ 480	460 rpm
BG2 100-330	13.5 hp	propeller HD+ 640	330 rpm
BG2 100-460	13.5 hp	propeler HD+ 500	460 rpm

galvanized, hardened steel and ss304

Bearing

2 tapered roller bearings to absorb the axial forces
 Mechanical seal SiC/SiC, independent of rotation direction
 Idler bearings in drive shaft

Ex-Zone

Ex-Zone 2 (outside)
 and Ex-Zone 1 (inside)
 Classification mechanical:
 II 2G Ex h IIA T3 Gb

Controls (optional)

Star-delta switch, soft start or frequency converter
 Delivery without connecting cable



GIANTMIX BG2

BG2 40-220

BG2 40-305

BG2 75-330

BG2 75-460

BG2 100-330

BG2 100-460

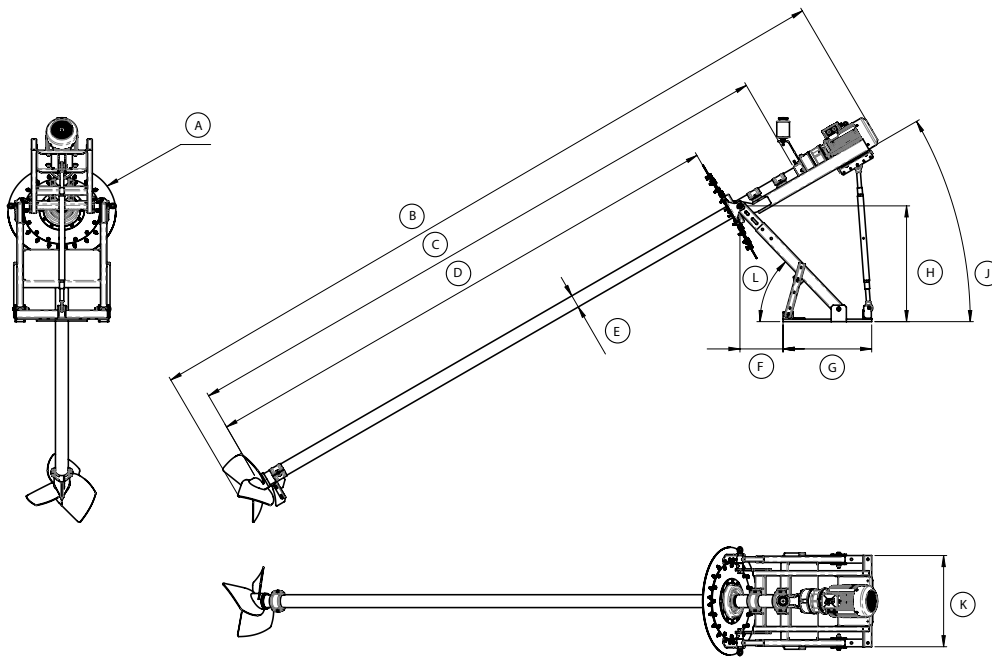

Dimensions

Type	A [in]	B [in]	C [in]	D [in]	E [in]	F [in]	G [in]	H [in]	J [°]	K [in]	L [°]
BG2	29.5	224.4	197	173.2	4	7-16.9	27.6	23.6 - 47.2	0° - 30°	28.3	30° - 62°

Technical data

Type	Rated power [hp]	Frequency [Hz]	Gear reduction ratio	Propeller speed [rpm]	Propeller diameter [in]	Axial force [lbf]	Flow velocity. [ft/s] *	Pumping rate Water [gal/min]	Weight approximate [lbs]
BG2 40-220	5.5	60	5.25	220	25.2	224.8	7.5	11,359	617.3
BG2 40-305	5.5	60	3.83	305	21.2	224.8	7.9	8,189	617.3
BG2 75-330	10	60	5.25	330	24.4	404.7	10.2	14,265	617.3
BG2 75-460	10	60	3.83	460	18.9	382.2	9.8	7,925	617.3
BG2 100-330	13.5	60	5.25	330	25.2	485.6	9.1	16,114	617.3
BG2 100-460	13.5	60	3.83	460	19.7	440.6			617.3

Subject to changes without notice

* measured in water and 3.94 ft distance

As per: 2023-08

© SUMA America Inc. | 2700 Patriot Blvd Suite 400 | Glenview, IL 60026

Phone: 312.912.1961 | Email: sales@gosuma.com | www.gosuma.com